



C2R-GM11b

GM Radio Replacement Interface for GMLAN 11-bit Vehicles Without OnStar®



This Interface is Intended for use in Vehicles without OnStar® or when OnStar® is not serviced or is unwanted. For OnStar® Retention use the OS-311b.

The C2R-GM11b allows aftermarket radio installation without retention of the factory radio. The interface replicates all factory warning chimes, audible turn signal indicators and provides a data bus generated 12 volt accessory output that acts just as GM's R.A.P. (Retained Accessory Power) system did prior to radio removal. R.A.P. keeps the radio powered after the key is off, until the driver door is opened or a 10 minute timer ends, whichever comes first. The C2R-GM11b will work with or without factory amplified audio systems.

Installation:

Connect the speaker level radio outputs to C2R-GM11b's speaker inputs. If the vehicle and the interface both chime, move the chime switch to the off position. The other wire connections are as follows:

- Yellow - 12 Volt Constant Voltage
- Black - Ground
- Red - 12 Volt R.A.P Voltage (1 AMP max)
- Blue/White - Antenna turn on, Amplifier turn on
- Orange - Dimmer/Illumination
- Lt. Green - SWC Output Wire

Using the SWC Output wire - Connect the SWC (green) output wire to a P.A.C. SWI interface. Use the green SWI interface wire and program the SWI interface for version 1. Do not cut the Brown loop.

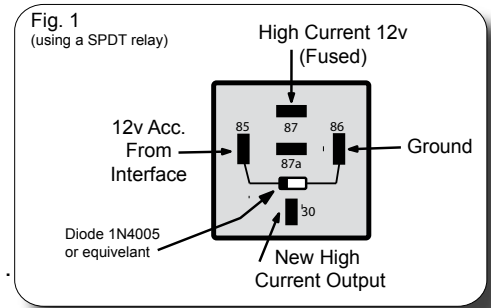

**If more than 1 AMP is needed from the Red +12v Accessory wire refer to Fig 1.

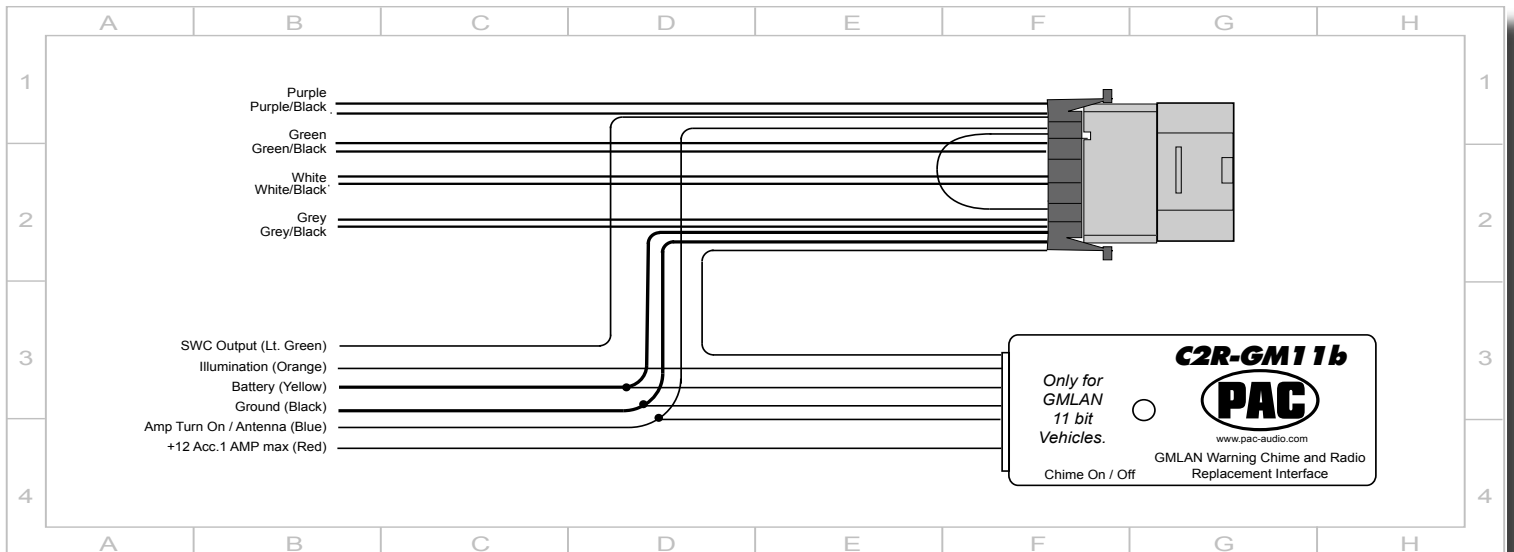

DISCLAIMER: Under no circumstances shall the manufacturer or the distributors of the C2R-GM11b parts be held liable for consequential damages sustained in connection with the C2R-GM11b. The manufacture and it's distributors will not, nor will they authorize any representative or any other individual to assume obligation or liability in relation to the C2R-GM11b other than its replacement.

GMLAN Vehicle Application Guide for Radio Replacement

Make	Model	Year	C2R-GM29	C2R-GM11	C2R-GM11b	OS-3	OS-3 BOSE	OS-311	OS-311b
Buick	Lucerne	2006-2007	X			X	X		
Cadillac	DTS	2007	X			X	X		
	Escalade	2007	X			X	X		
	SRX	2007	X			X	X		
Chevy	Avalanche	2007	X			X	X		
	Cobalt	2007		X				X	
	Cobalt	2005-2006			X				X
	Equinox	2007	X			X			
	HHR	2006-2007		X				X	
	Impala	2006-2007	X			X	X		
	Malibu	2004-2007			X				X
	Monte Carlo	2006-2007	X			X			
	Silverado (Non Classic)	2007	X			X	X		
	Suburban	2007	X			X	X		
	Tahoe	2007	X			X	X		
GMC	Acadia	2007	X			X	X		
	Denali (Sierra and Yukon)	2007	X			X	X		
	Sierra (Non Classic)	2007	X			X	X		
	Yukon	2007	X			X	X		
Pontiac	G5	2007		X				X	
	G6	2005-2007			X				X
	Solstice	2006-2007		X				X	
	Torrent	2007	X			X			
Saturn	Aura	2007		X				X	
	Outlook	2007	X			X			
	Sky	2007		X				X	